

WARNING: THE MINIMUM SPEAKER IMPEDANCE IS 4 OHMS EACH.

IF YOU CONNECT AND USE THE MA251 WITH A LOWER SPEAKER IMPEDANCE THAN LISTED ABOVE YOU WILL DAMAGE THE UNIT AND POSSIBLY OTHER EQUIPMENT THAT IS CONNECTED TO THE MA251.

SPECIFICATIONS:

Line Input Impedance:	10K Ohms Line 600 Ohms Mic.
Power Output:	5 Watts X 2 (4 Ohms)
Voltage Gain:	55 dB Mic 30 dB Line
Maximum Supply Voltage:	24 VDC
THD:	.05% typical
EIN:	3 mV
Efficiency:	85%
Input Sensitivity:	28 mV
Bandwidth:	20Hz - 25 kHz +/- 3dB
+Size:	6.75" x 3.5" x 1.5"
Weight:	1 lb.



ROLLS

MA251

5 + 5 watt

Mixer/Amplifier

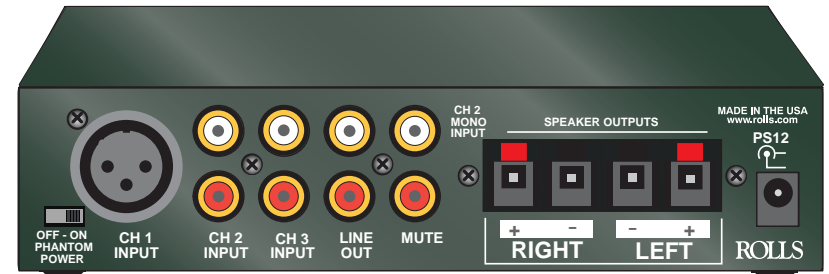

- RCA Inputs, XLR Mic with Phantom Power
- Volume controls for each Channel
- Low noise, efficient operation
- Small compact size
- Class D high efficiency amp

The MA251 is a very compact 5 + 5 watt high efficiency amp with a four channel stereo mixer built in. Left and Right stereo speaker outputs. The unit is perfect for small speakers in small environments. Great for in ceiling and projector applications where small size is needed along with class D low radiated heat locations.

Connection guide

INTRODUCTION

Thank you for your purchase of the MA251. The MA251 is a four channel mixer/ amplifier designed for Audio and Visual applications. Channels 1 has a microphone XLR input with switchable phantom power. Channel 2 has stereo and mono RCA inputs. Channel 3 has RCA stereo inputs and channel 4 has a 3.5mm stereo input. The MA251 is intended for professional applications. It has a FR4(V94-0) rated glass epoxy circuit board, and a powder coated steel chassis. All inputs except CH 1 microphone and Ch MONO input are stereo. Outputs for Speaker and Line are true stereo.

NOTE: THIS MANUAL ASSUMES THE USER HAS A WORKING KNOWLEDGE OF AUDIO ELECTRONICS, BALANCED AND UNBALANCED CONNECTIONS, AND PROPER SIGNAL LEVEL SETTING.

INSPECTION / WARRANTY

1. Unpack and inspect the MA251 box and package. If obvious physical damage is noticed, contact the carrier immediately to make a damage claim. We suggest saving the shipping carton and packing materials for safely transporting the unit in the future.
2. Please visit our web site at www.rolls.com and click on the Register Your Warranty Here button.

DESCRIPTION

REAR PANEL

SPEAKER OUTPUT: Push terminals for speaker wire.

PS12: For connection to the power supply.

INPUTS: RCA line level inputs and a balanced XLR mic input for CH1.

MUTE JACK: By shorting out the RCA jack labeled MUTE, the Speaker Outputs will be muted.

XLR INPUT: For connection to a microphone.

PHANTOM POWER SWITCH: Switches the Phantom Power on or off for a condenser mic on channel 1.

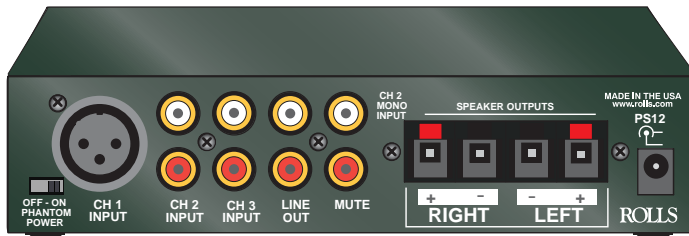

FRONT PANEL

CHANNEL VOLUME: Adjusts the level of signal from the Line Input to the Line out RCA's and Speaker outputs.

3.5mm JACK: For connection to an ipod, MP3 player or computer TRS Stereo (left, right and ground) connection to channel 4

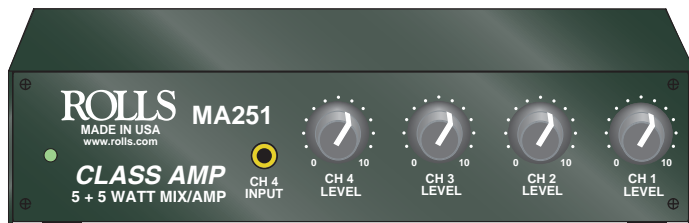

CHANNEL DESCRIPTION

CH 1 INPUT: XLR jack for connection to a microphone. Switchable phantom power as labeled on unit.

CH 2 INPUTS: Stereo RCA and one mono RCA for connection to a signal source such as a CD player, cassette deck, tuner, etc.. PLEASE NOTE WITH A MONO INPUT AS WELL AS A STEREO INPUT, CHANNEL 2 AT CERTAIN IMPEDANCES ON THE STEREO INPUT YOU MAY EXPERIENCE CROSS TALK BETWEEN THE LEFT AND RIGHT. THIS IS NORMAL OPERATION AND SHOULD BE EXPECTED.

CH 3 INPUT: Stereo RCA jack for connection to a signal source such as a CD player, cassette deck, tuner, etc.

CH4 INPUT: For connection to a stereo 3.5mm(1/8" jack).

LINE OUT: Stereo RCA jacks for connection to a mixer or amplification device.

CONNECTION / OPERATION

To operate the MA251, properly connect cords from the sources to be mixed (mics, cassette decks, CD players etc.) into the channel inputs. Connect the speaker outputs to 4 Ohm or higher impedance speakers. Adjust the channel level controls for the desired volume.

SCHEMATIC

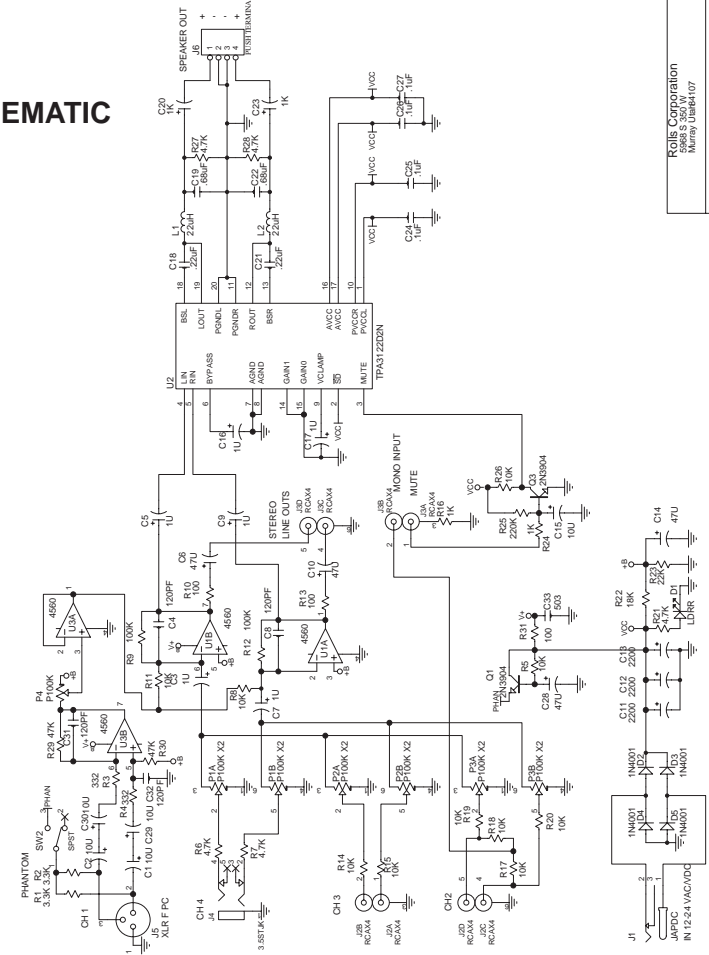

Rolls Corporation	
9908 S 350A Vio	
Mummy 0366107	
Title	MA251 CLASS MIXER/AMPLIFIER
Size	Rev: _____
Drawn	21 October 2009
Sheet	1 of 1